



**TI57 Thermal Insulation  
for EH5700 Series Enclosures**

**Installation/Operation  
Manual C1433M (6/95)**

**1.0 WARNINGS**

Prior to installation and use of this product, the following WARNINGS should be observed.

1. Installation and servicing should only be done by Qualified Service Personnel and conform to all Local codes.
2. Unless the unit is specifically marked as a NEMA Type 3, 3R, 3S, 4, 4X, 6, or 6P enclosure, it is designed for indoor use only and it must not be installed where exposed to rain and moisture.
3. Only use replacement parts recommended by PELCO.
4. After replacement/repair of this unit's electrical components, conduct a resistance measurement between line and exposed parts to verify the exposed parts have not been connected to line circuitry.

**2.0 SCOPE**

The information contained in this manual covers the TI57 Thermal Insulation Kit Installation.

**2.1 DESCRIPTION**

The TI57 Thermal Insulation Kit provides an improved resistance to heat loss through the body of the enclosure by adding a 1/4-inch thick polyurethane insulation to the majority of the internal surfaces.

### 3.0 TI57 THERMAL INSULATION

**NOTE:** The camera mounting sled must be removed for proper installation of the thermal insulation, therefore, it should be done prior to the enclosure installation. (- 1, -2, -3; heater/blower/wiper kits must be removed prior to thermal insulation installation.)

The TI57 thermal insulation sheets are designed to be used with both 23-inch and 29-inch EH5700 and EH5700L Series enclosures. If insulation is required for an 23-inch enclosure, the excess insulation must be removed along the factory-marked perforation. For 29-inch installations, no trimming is necessary. To install the thermal insulation, perform the following steps:

#### 3.1 BODY INSULATION INSTALLATION

1. Remove the necessary punch-out cable-feed pieces from the insulation pad depending on the type of enclosure (EH5700 or EH5700L series) being used. Remove the vent area pieces for (-1, -2, -3) ventilation through the enclosure. (See Figures 1 and 2.)
2. To adjust the length of the insulation pad, tear the insulation along the perforations from the end of the pad to fit either the 23-inch standard or Legacy® version of the enclosure.
3. Position the pad around the press nuts in the center of the body by folding the pad along its length. Position the insulation punch-out(s) to closely match the position of the press nuts.

4. Remove the adhesive backing, and carefully lay the insulation in the body of the enclosure, pressing firmly, taking care not to crease the insulation.
5. The insulation is very soft and will conform as needed during the installation of the camera and lens.

#### 3.2 LID INSULATION INSTALLATION

1. Unlatch the enclosure lid and raise.
2. Pop the gas spring off of the lid at the ball-joint connection. Make sure the lid is supported and not allowed to lay completely open - doing so will damage the lid hinge.
3. Remove the punch-out pieces from the insulation pad that accommodate the sun shroud screws and the lid arm on the inside of the enclosure lid.
4. Adjust the necessary length of the pad according to the length of the enclosure.
5. Remove the adhesive backing, and carefully lay the insulation in the lid of the enclosure, pressing firmly, taking care not to crease the insulation.
6. Position the insulation around the sun shroud fasteners on the inside of the lid. It may help to hold the insulation in a folded manner while positioning.
7. Snap the gas spring ball joint to the lid, close the enclosure.

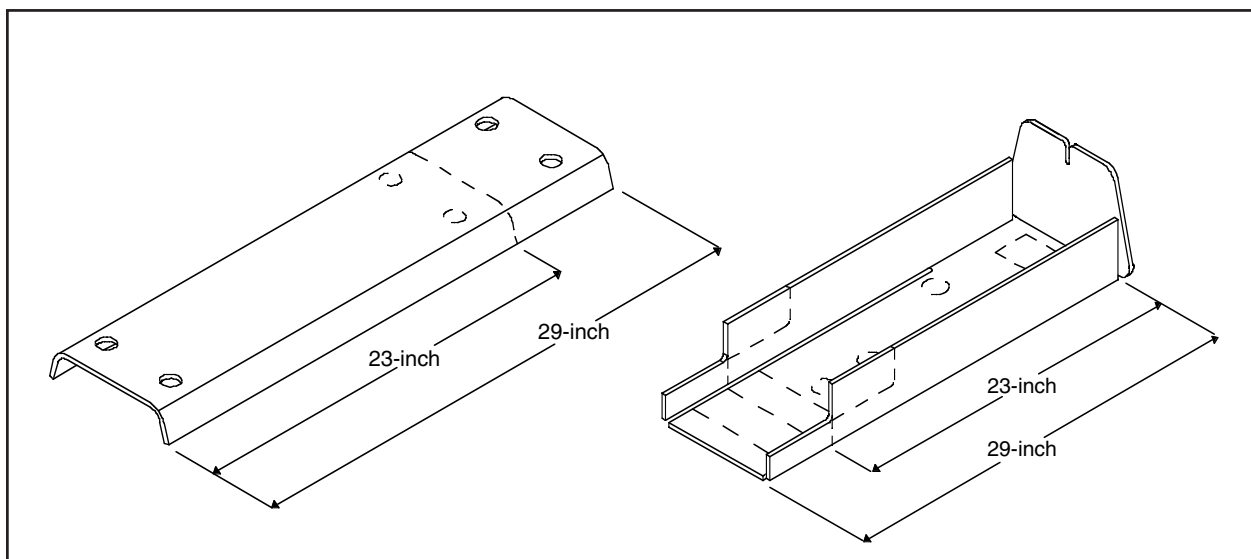

**Figure 1.** Lid and Body Insulation Sheets

**NOTE:** When using blanking plates (in extreme cold conditions), leave the vent/blanking plate area of the insulation in place for extra protection.

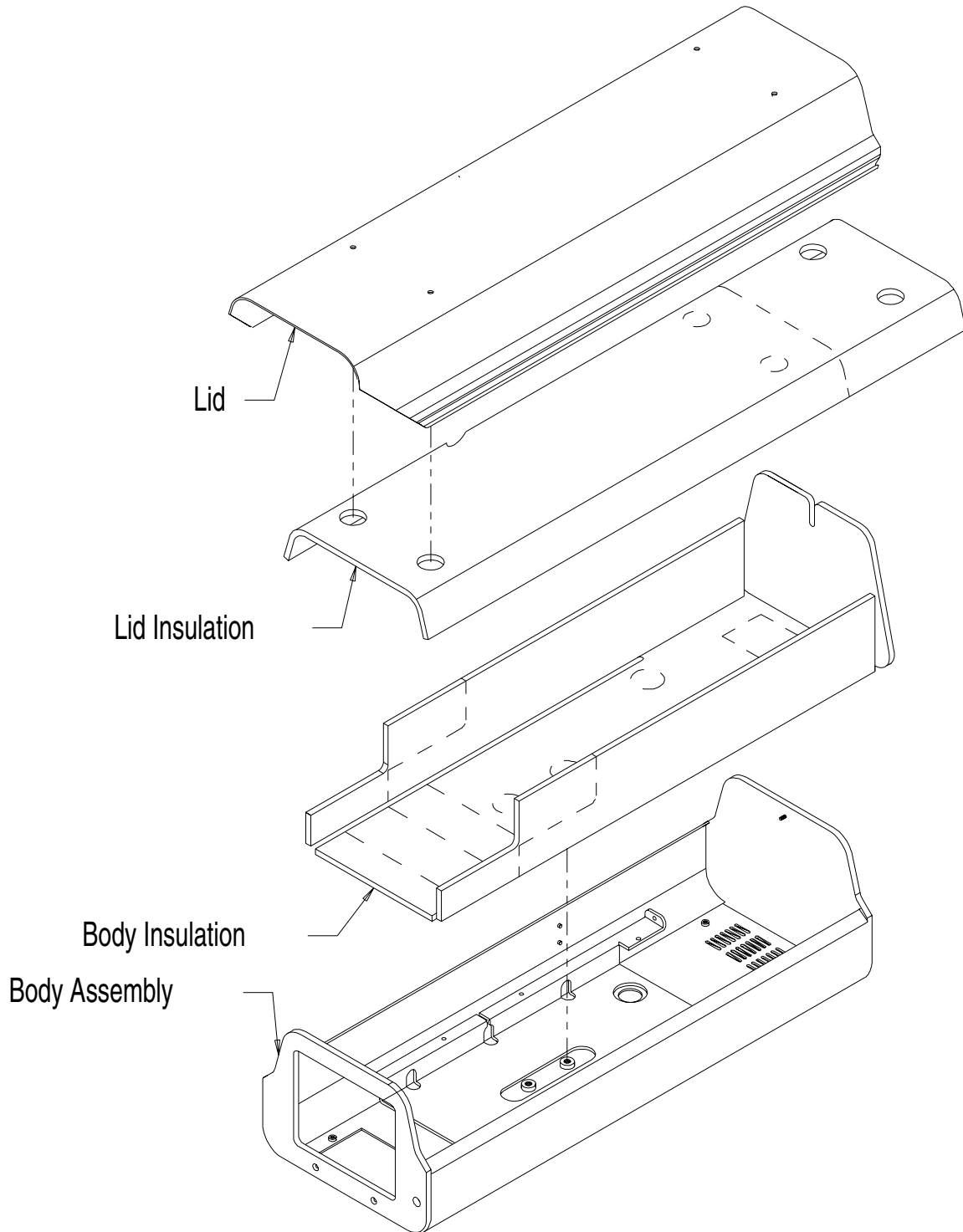

**Figure 2.** T157 Thermal Insulation Installation

## 4.0 WARRANTY AND RETURN INFORMATION

### WARRANTY

Pelco will repair or replace, without charge, any merchandise proved defective in material or workmanship for a period of one year after the date of shipment.

Exceptions to this warranty are as noted below:

- Five years on FT/FR8000 Series fiber optic products.
- Three years on Genex® Series products (multiplexers, server, and keyboard).
- Three years on Camclosure® and fixed camera models, except the CC3701H-2, CC3701H-2X, CC3751H-2, CC3651H-2X, MC3651H-2, and MC3651H-2X camera models, which have a five-year warranty.
- Two years on standard motorized or fixed focal length lenses.
- Two years on Legacy®, CM6700/CM6800/CM9700 Series matrix, and DF5/DF8 Series fixed dome products.
- Two years on Spectra®, Esprit®, ExSite™, and PS20 scanners, including when used in continuous motion applications.
- Two years on Esprit® and WW5700 Series window wiper (excluding wiper blades).
- Eighteen months on DX Series digital video recorders, NVR300 Series network video recorders, and Endura™ Series distributed network-based video products.
- One year (except video heads) on video cassette recorders (VCRs). Video heads will be covered for a period of six months.
- Six months on all pan and tilts, scanners or preset lenses used in continuous motion applications (that is, preset scan, tour and auto scan modes).

Pelco will warrant all replacement parts and repairs for 90 days from the date of Pelco shipment. All goods requiring warranty repair shall be sent freight prepaid to Pelco, Clovis, California. Repairs made necessary by reason of misuse, alteration, normal wear, or accident are not covered under this warranty.

Pelco assumes no risk and shall be subject to no liability for damages or loss resulting from the specific use or application made of the Products. Pelco's liability for any claim, whether based on breach of contract, negligence, infringement of any rights of any party or product liability, relating to the Products shall not exceed the price paid by the Dealer to Pelco for such Products. In no event will Pelco be liable for any special, incidental or consequential damages (including loss of use, loss of profit and claims of third parties) however caused, whether by the negligence of Pelco or otherwise.

The above warranty provides the Dealer with specific legal rights. The Dealer may also have additional rights, which are subject to variation from state to state.

If a warranty repair is required, the Dealer must contact Pelco at (800) 289-9100 or (559) 292-1981 to obtain a Repair Authorization number (RA), and provide the following information:

1. Model and serial number
2. Date of shipment, P.O. number, Sales Order number, or Pelco invoice number
3. Details of the defect or problem

If there is a dispute regarding the warranty of a product which does not fall under the warranty conditions stated above, please include a written explanation with the product when returned.

Method of return shipment shall be the same or equal to the method by which the item was received by Pelco.

### RETURNS

In order to expedite parts returned to the factory for repair or credit, please call the factory at (800) 289-9100 or (559) 292-1981 to obtain an authorization number (CA number if returned for credit, and RA number if returned for repair).

All merchandise returned for credit may be subject to a 20% restocking and refurbishing charge.

Goods returned for repair or credit should be clearly identified with the assigned CA or RA number and freight should be prepaid. Ship to the appropriate address below.

If you are located within the continental U.S., Alaska, Hawaii or Puerto Rico, send goods to:

Service Department  
Pelco  
3500 Pelco Way  
Clovis, CA 93612-5699

If you are located outside the continental U.S., Alaska, Hawaii or Puerto Rico and are instructed to return goods to the USA, you may do one of the following:

If the goods are to be sent by a COURIER SERVICE, send the goods to:

Pelco  
3500 Pelco Way  
Clovis, CA 93612-5699 USA

If the goods are to be sent by a FREIGHT FORWARDER, send the goods to:

Pelco c/o Expeditors  
473 Eccles Avenue  
South San Francisco, CA 94080 USA  
Phone: 650-737-1700  
Fax: 650-737-0933



### PELCO

3500 Pelco Way  
Clovis, CA 93612-5699 USA  
(559) 292-1981 • (800) 289-9100  
FAX (800) 289-9150 or (559) 292-3827

International customers call 1-559-292-1981 or  
FAX 1-559-348-1120

(Product specifications subject to change  
without notice.)

### C1433M

Pelco, the Pelco logo, Camclosure, Esprit, Genex, Legacy, and Spectra are registered trademarks of Pelco.  
Endura and ExSite are trademarks of Pelco.

© Copyright 1995, Pelco. All rights reserved.